

-DEPFILAWP-HR series

Draw Wire sensor - High Resolution

Ref: 4224

Rev: A



DESCRIPTION

DEPFILAWP-HR series High Resolution draw wire sensors make measurements by pulling and rewinding the stainless-steel wire (stroke lengths up to 1200 mm). The linear motion is converted to analog or CANopen output.

This compact and robust instrument is easy to install, and may serve many industrial applications, such as: Material Handling & Lifting Systems (elevators, lifting platforms, forklifts...), Processing & Manufacturing Machinery (wood/glass/paper/metal sheet/injection... machines), Automation, Robotics & Positioning (Industrial robots, X-Y axis displacement, Horizontal control equipment...), Hydraulic and Pneumatic systems (air compressor, dam protections, press...), Measurement, Control & Quality (Liquid level measurements and position control...).

MECHANICAL DATA

Stroke (measuring) Length	For analog output: 400...1200 mm For CANopen output: 0...1200 mm
Maximum Speed	2 m/s
Required Force	5 N
Linearity	±0.25% FS
Operating Temperatures	-25°C ... +85°C
Relative Humidity	10%...90%
Weight	~460 gr
Protection Class	IP67
Construction Material	Housing: Aluminum Measuring Wire: Stainless steel

MECHANICAL DIMENSIONS

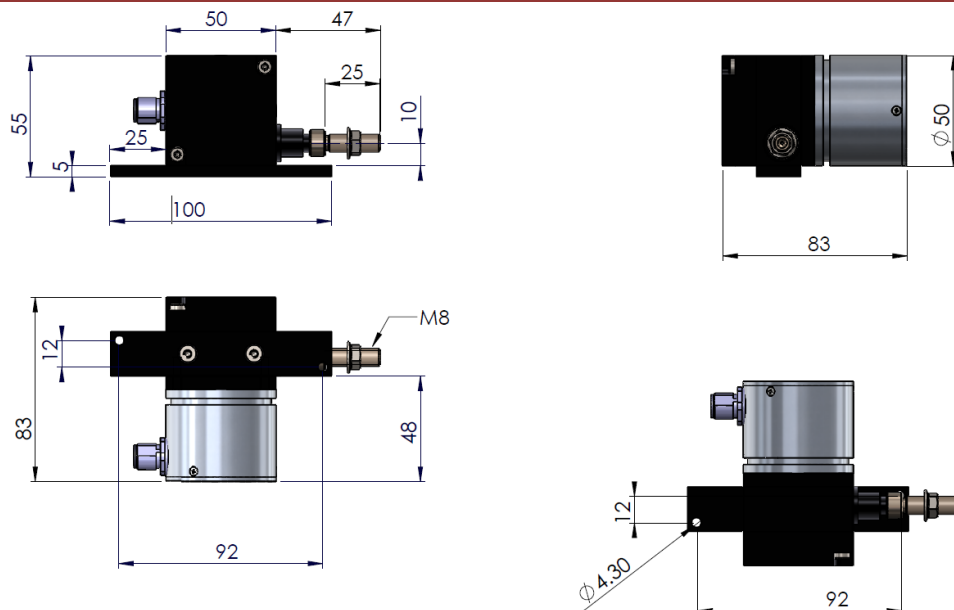

TECHNICAL CONNECTION

ANALOG VERSION

Electrical Features	
Measuring Range	400...1200 mm
Working Principle	Hall effect
Output Signal	Voltage: 0-10V, 0.5-4.5V, 0-5V Current: 4-20 mA
Signal characteristics	Increasing (ex: 4-20 mA) Decreasing (ex:20-4 mA)
Supply Voltage	15 ... 26 VDC
Current Consumption	≤60 mA
Output load	For current output; min 250 Ω For voltage output; min 1 KΩ
Resolution	16 bit
Response Frequency	500 Hz
Reverse Polarity Protection	Yes
Short circuit protection	Yes (only supply)
Electrical Connection	M12/5 pin male connector

Electrical Connection		
Signal	Cable	M12 5 Pin Male Connector
V+ (15...26 VDC)	Red	Pin 1
Analog output signal	Yellow	Pin 2
GND	Black	Pin 3
N/C	Green	Pin 4
N/C	Pink	Pin 5

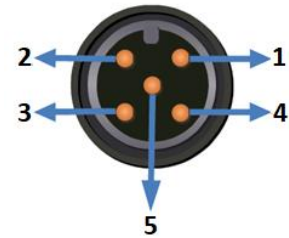

Order Information:

-DEPFILAWP-HR

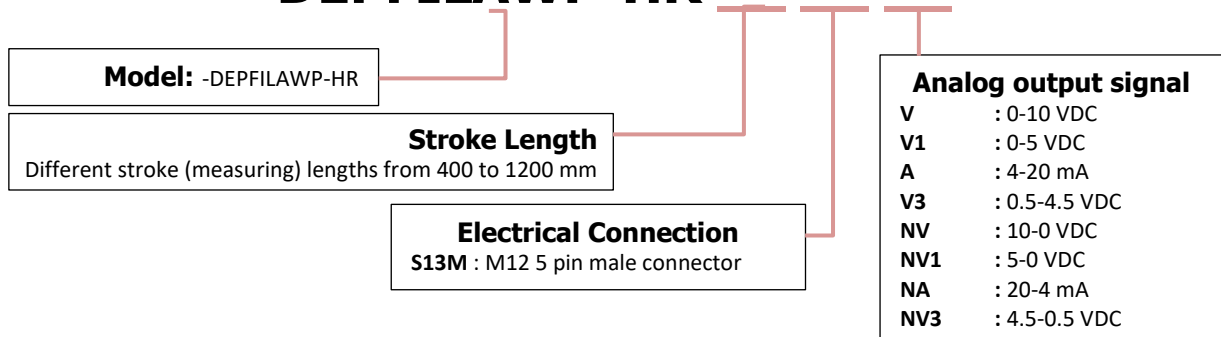

ANALOG VERSION, PROGRAMMABLE

Electrical Features	
Measuring Range	400...1200 mm
Working Principle	Hall effect
Output Signal	Voltage: 0-10V, 0.5-4.5V, 0-5V (programmable) Current: 4-20 mA (programmable)
Signal characteristics	Increasing (ex: 4-20 mA) Decreasing (ex:20-4 mA)
Supply Voltage	15 ... 26 VDC
Current Consumption	≤60 mA
Output load	For current output; min 250 Ω For voltage output; min 1 KΩ
Resolution	16 bit
Response Frequency	500 Hz
Reverse Polarity Protection	Yes
Short circuit protection	Yes (only supply)
Electrical Connection	M12/5 pin male connector

Electrical Connection		
Signal	Cable	M12 5 Pin Male Connector
V+ (15...26 VDC)	Red	Pin 1
Analog output signal	Yellow	Pin 2
GND	Black	Pin 3
N/C	Green	Pin 4
SPAN/ZERO	Pink	Pin 5

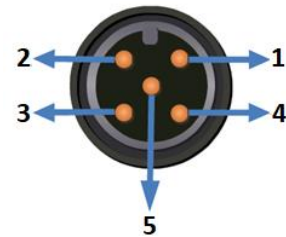

SETTING MEASUREMENT LIMITS: With this feature, you can set the minimum and maximum measurement limits. To determine the **minimum measurement limit (lim1)**, the SPAN/ZERO and GND terminal are short-circuited for at least 3 seconds. To determine the **maximum measurement limit (lim2)**, the SPAN/ZERO and GND terminal are short-circuited for at least 6 seconds. To **return to the factory settings**, the SPAN/ZERO and GND terminal are short-circuited for at least 10 seconds.

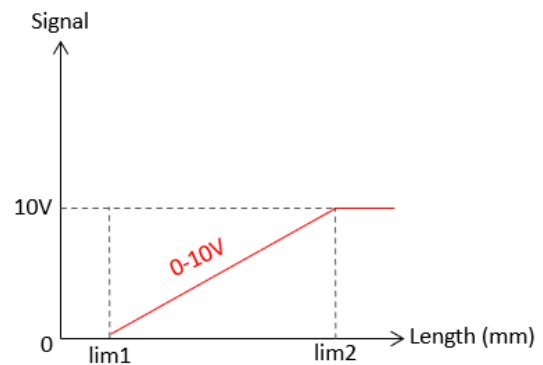
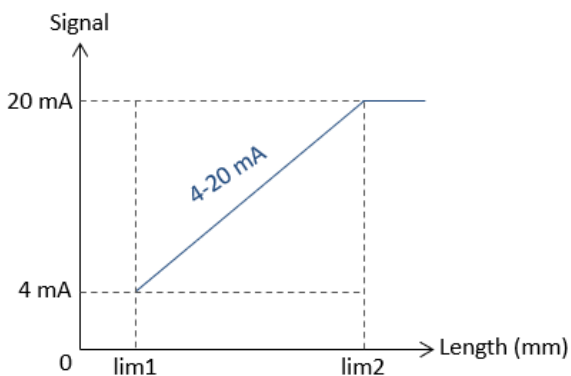
SAMPLE SIGNAL OUTPUT GRAPHICS

Order Information:

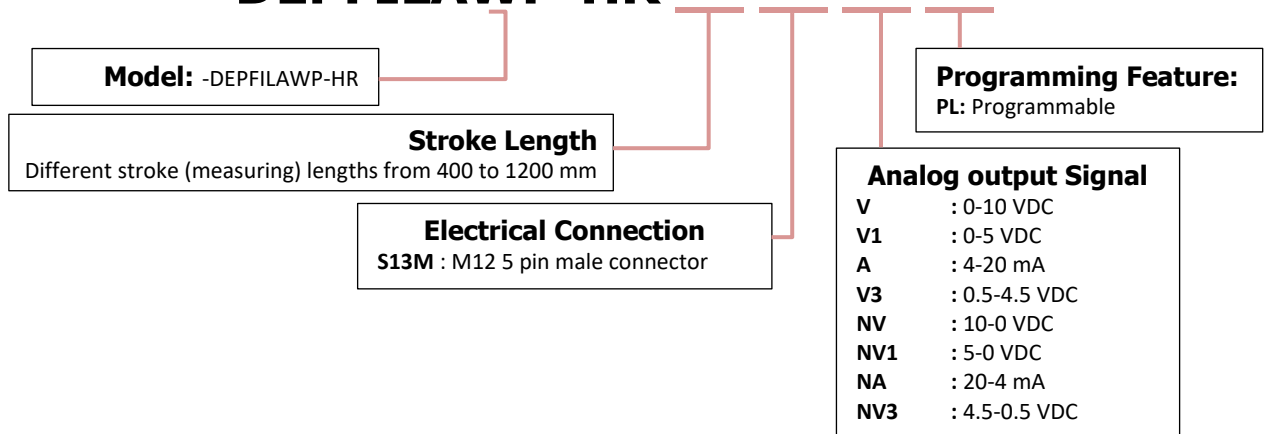
-DEPFILAWP-HR

CANOPEN VERSION**Electrical Features**

Measuring Range	0...1200 mm
Working Principle	Hall effect
Supply Voltage	12 ... 30 VDC
Current Consumption	≤60 mA
Resolution	6µm
Response Frequency	500 Hz
Reverse Polarity Protection	Yes
Short circuit protection	Yes (only supply)
Electrical Connection	M12/5 pin male connector

CANopen Features

Communication Profile	CiA 301
Device Type	CANopen, CiA DS406
Node ID	Adjustable from 1 to 127 with LSS or SDO
Baud Rate	10 kBit/s, 20 kBit/s, 50 kBit/s, 100 kBit/s, 125 kBit/s, 250 kBit/s, 500 kBit/s, 800 kBit/s, 1 Mbit/s
PDO Data Rate	100 ms
Error Control	Heartbeat, Emergency Message
PDO	3 Tx PDO
PDO Modes	Event/Time triggered, Synch/Asynch
SDO	1 server
Position Information	Object Dictionary 0x6020
Termination Resistance	Optional 120Ω

Electrical Connection

Signal	Cable	M12 5 Pin Male Connector
V+ (15...26 VDC)	Red	Pin 1
Analog output signal	Yellow	Pin 2
GND	Black	Pin 3
N/C	Green	Pin 4
SPAN/ZERO	Pink	Pin 5

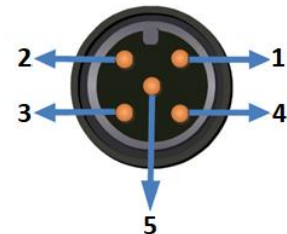
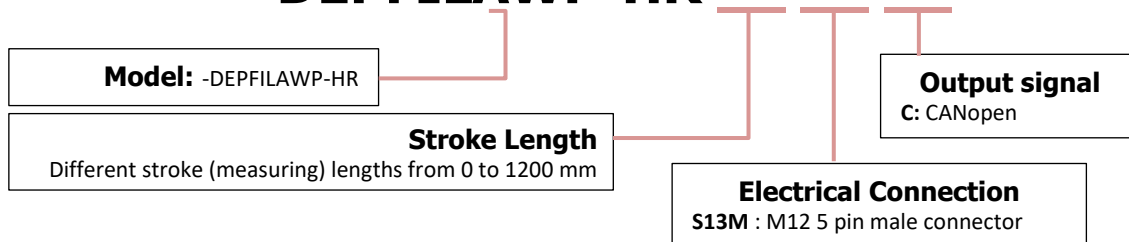
**Order Information:****-DEPFILAWP-HR**

MOUNTINGS AND WARNINGS

1. Never release the wire after pulling. Otherwise, the coil spring will be damaged.

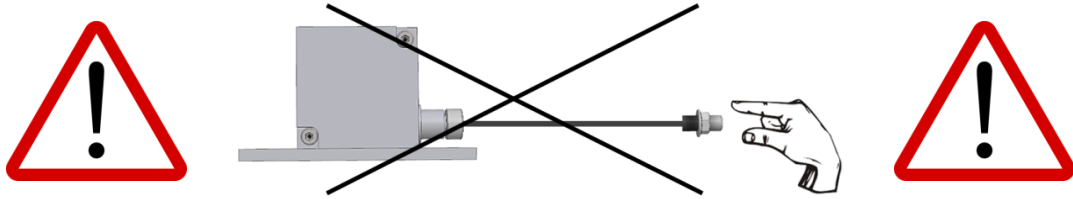

2. Mount the sensor according to the mounting directions shown below.

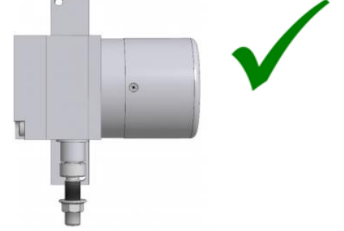

3. If case of rain or water trickle, the wire outlet should always face water downstream. If necessary, use guide rollers

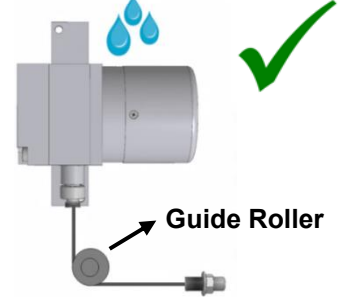

4. The wire should always be pulled out in straight line (no angle). If necessary, use guide rollers.

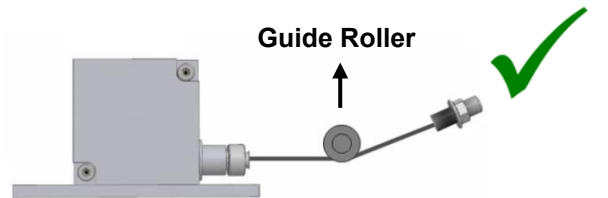
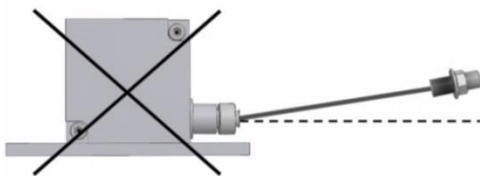

Important Note: In case of non-compliance with these recommendations, any malfunctions that may occur will not be covered by the warranty.

REVISIONS HISTORY

REVISION	DATE	DESCRIPTION
A	18/07/2025	Creation of the document

CONTACT

MESUREX
 13 Rue des Corroyés
 78730 Saint Arnoult en Yvelines (France)

Tel : +33 (0) 1 30 41 23 62
 Mail : mesurex@mesurex.fr
 Web : www.mesurex.fr