

-LDS series

Laser Distance Sensor

Ref : 4231

Rev : A



DESCRIPTION

LDS series is used in various applications to measure a distance, control motion, verify position, detect an obstacle, monitor altitude...

It determines precisely the distance between the sensor and the object through the flight time of the light, just by sending the laser beam and receiving it back from the reflective surface / reflector. The time difference between sending and receiving the beam indicates the actual distance of the target in millimeters.

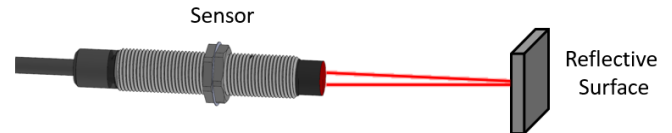

LDS series laser distance sensors are quickly mounted with their small and compact structure, and easily adapt to your system with Analog, switch, CANopen and MODBUS interface options.

TECHNICAL DATA

OPTICAL DATA				
Working Principle	Time-of-Flight, reflected from reflector			
Measuring Distance	Selectable up to 2000 mm according to user preference			
Light Type	Invisible Laser (VCSEL), Class2			
Wavelength	940 nm			
Field Of View	18°			
Recommended Reflector Size	5x5cm for distance ≤1000mm 10x10cm for distance >1000mm (10x10cm reflector provided as standard in the set)			
Max. Permissible external light	1000 lux (effected by intense sunlight)			
ELECTRICAL DATA				
Supply	Analog 12...30 Vdc	CANopen	RS-485 6...30 Vdc	Switch*
Output Types	0-10V, 0-5V, 0.5-4.5V 0-20mA, 4-20mA	CANopen	RS-485	Switch (1 x PNP open collector)**
Power Consumption	0,24 Watt max.			
Current Consumption	10mA @24VDC max			
Sampling Rate	Analog	CANopen 20 Hz	RS-485	Switch* 100 Hz
Accuracy	For products with Measuring Distance ≤ 1000mm For products with Measuring Distance >1000mm		±0.5% ±2%	
Repeatability	≤ ±1mm			
Minimum Resolution	1 mm			
Analog Output Load	500 Ω			
Analog Output Resolution	12 Bit (1 mm resolution)			
Indicator	RGB LED			
Reverse Polarity Protection	Yes			
Temperature Compensation	Yes			
Watchdog	Yes			
Typical operating lifetime	50,000 hours (under continuous 24/7 use)			

* **Completely insulated switch output:** Switch output can be fed from a separate source. Between 6-30 volts, the device can be powered by a source independent of the power source.

** **Switch short circuit protection:** Maximum current limit of 200mA. When it reaches the 200mA current limit, the device cuts off the switch output. It ensures the protection of the source and connected devices. In order for the device to start giving output again, the short circuit condition must be eliminated and the device must be restarted.

MECHANICAL DATA

Protection Class	IP67
Operating Temperature	-20...+85°C
Storage Temperature	-20...+85°C
Material	Body: Nickel plated brass / Cable: PVC
Electrical Connection	Cable or M12 connector

RS-485 FEATURES

Communication Protocol	Modbus RTU
Baud Rate	600, 1200, 2400, 4800, 9600, 14400, 19200, 38400, 57600, 115200 Default: 9600
Parity	None, Odd, Even Default: None
Adres	Between 1 and 247 Default: 1

CANopen FEATURES

Communication Profile	Ds406
Response Frequency	20 Hz.
Device Type	CANopen, DS406
Node ID	Between 1 and 127, it can be set with LSS or SDO Default: 1
Baud Rate	10 kBit/s, 20 kBit/s, 50 kBit/s, 100 kBit/s, 125 kBit/s, 250 kBit/s, 500 kBit/s, 800 kBit/s, 1 Mbit/s Default: 250 kBit/s
PDO Data Rate	100 ms
Error Check	Heartbeat, Emergency Message
PDO	1 Tx PDO
PDO Modes	Event/Time triggered, Synch/Asynch
SDO	1 server
Position data	Object Dictionary 6004
Terminating Resistor	No

MECHANICAL DIMENSIONS (mm)

With cable:

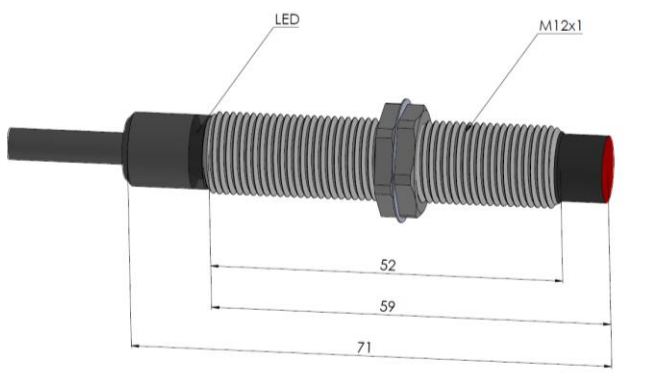

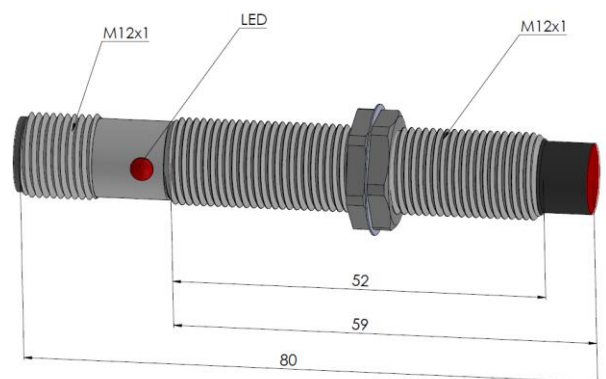

With M12 Connector:

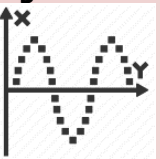
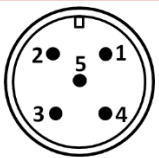

ELECTRICAL CONNECTION

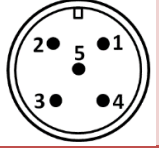
ANALOG OUTPUT (0-10V, 0-20mA, 4-20mA)		
Signal	M12-5 Pin Male Conn.	Cable
		
+V (12...30VDC)	Pin 1	Red
GND	Pin 2	Black
Analog Out +	Pin 3	Yellow
N/C	Pin 4	Green
N/C	Pin 5	Pink

RS-485 MODBUS OUTPUT		
Signal	M12-5 Pin Male Conn.	Cable
		
+V (12...30VDC)	Pin 1	Red
GND	Pin 2	Black
RS485 - B	Pin 3	Yellow
RS485 - A	Pin 4	Green
N/C	Pin 5	Pink

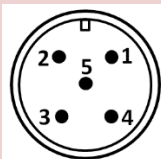
CANopen OUTPUT		
Signal	M12-5 Pin Male Conn.	Cable
		
CAN SHIELD	Pin 1	CAN SHIELD
+V (12...30VDC)	Pin 2	Red
GND	Pin 3	Black
CAN_H	Pin 4	Yellow
CAN_L	Pin 5	Green

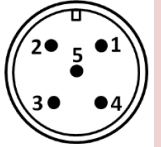
SWITCH OUTPUT (PNP OPEN COLLECTOR)		
Signal	M12-5 Pin Male Conn.	Cable
		
+V Cihaz (6...30VDC)	Pin 1	Red
GND Device	Pin 2	Black
+V Switch (6...30VDC)	Pin 3	Yellow
GND Switch	Pin 4	Green
Switch Out	Pin 5	Pink

Completely insulated switch output: Switch output can be fed from a separate source. Between 6-30 volts, the device can be powered by a source independent of the power source.

Switch short circuit protection: There is a maximum current limit of 200mA. When it reaches the 200mA current limit, the device cuts off the switch output. It ensures the protection of the source and connected devices. In order for the device to start giving output again, the short circuit condition must be eliminated and the device must be restarted.

LED INDICATOR

There is 1 RGB LED indicator on the device. This LED color and blinking speed changes depending on normal operation, error and configuration situations.

- **Normal Operating Status:** When the device is in normal operating mode, the LED indicator flashes green once per second.
- **Error Status:** If the maximum measurement distance is exceeded, the Red LED flashes once a second. If there is insufficient light reflection, the blue LED will flash once per second. If the blue and red LEDs flash together, this indicates that two errors are present at the same time.
- **Configuration Status with Magnet:** While the device is configured with a magnet, when it starts to detect the magnet, the LED color changes depending on the setting menu it is in (analog output or switch setting). LED color indicates which setting menu you are in and which setting can be made. As long as the magnet is detected, the blinking speed of the LED increases, flashing 10 times per second. Blinks for one second unless the magnet is detected.

ANALOG OUTPUT CONFIGURATION WITH MAGNET

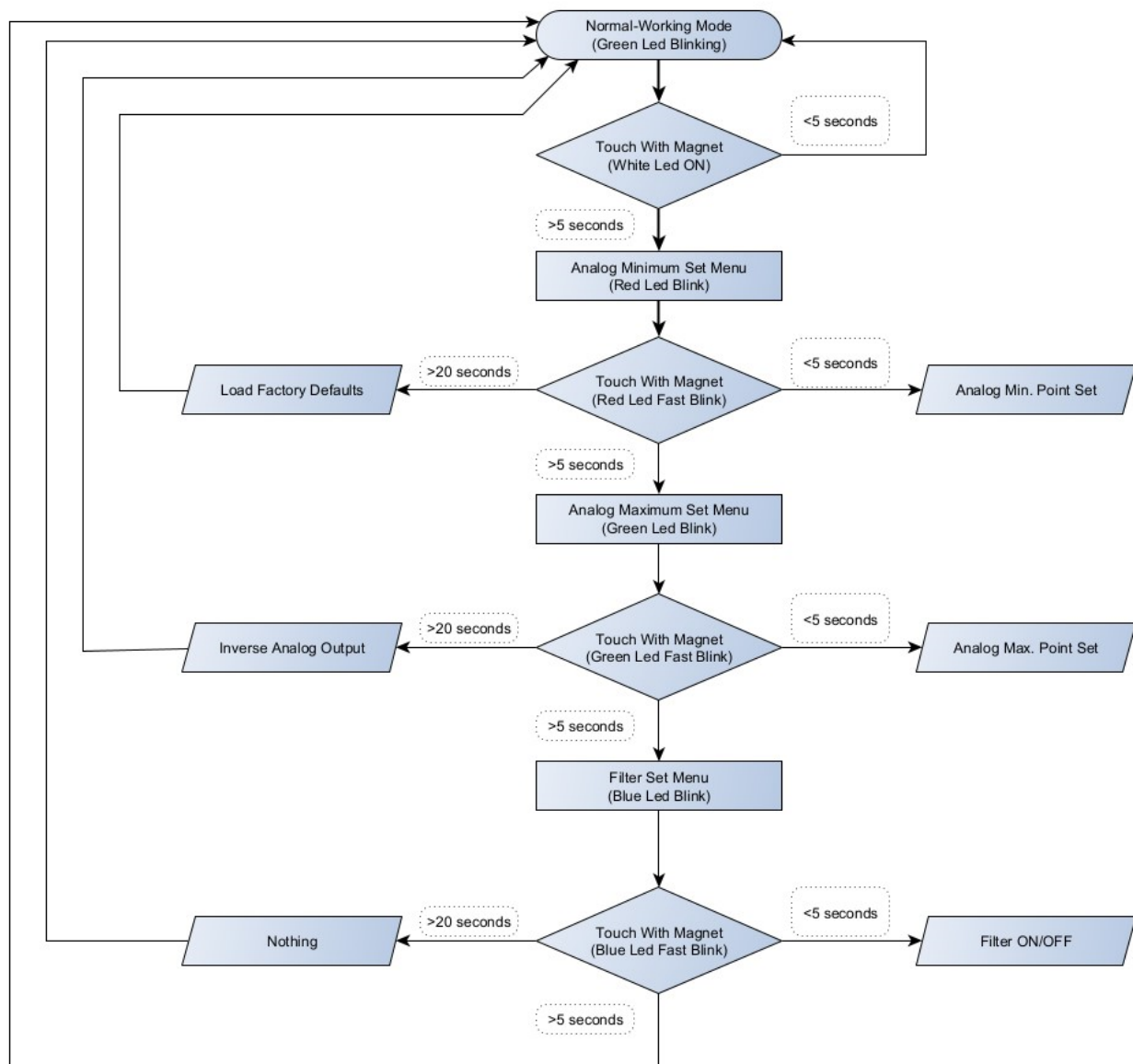

Zone where the adjustment magnet is approached

1. Setting the analog output minimum point:

Depending on output type; the distance at which the minimum analog value will be given is set.

When the device is in Normal Operation mode, the magnet is held to the magnetic reader area while the Green LED flashes for one second. If the magnet is detected, the sign LED starts to emit white light. If the magnet is held for more than 5 seconds, the device enters the menu where the analog minimum set point will be adjusted. In this case, the indicator LED starts to blink red and at one-second intervals.

Operations that can be done in this menu;

- **Setting the analog minimum point at the desired distance:** The LDS is positioned at the position where minimum analog output is desired. The magnet is read for a period of time greater than 1 second and less than 5 seconds.
- **-Go to next menu:** The magnet is read for more than 5 seconds. If the analog minimum point is not set at this stage, the point that was previously set as the analog minimum point will be valid.
- **-Return to factory settings:** If the magnet is read for more than 20 seconds, it restores the analog minimum, analog maximum, switch point1, switch point2 points made when the device was delivered to the user. The device exits the settings menus and returns to normal operating mode.

2. Setting the analog output maximum point:

Depending on output type; the distance at which the maximum analog value will be given is set.

If the magnet is read for more than 5 seconds and less than 15 seconds while the sign LED is red and flashing at one-second intervals, this menu is entered. The indicator LED starts blinking green and at one-second intervals.

Operations that can be done in this menu;

- **Setting the analog maximum point at the desired distance:** The LMS is positioned at the position where maximum analog output is desired. The magnet is read for a period of time greater than 1 second and less than 5 seconds.
- **-Inverting analog output:** If the magnet is read for more than 20 seconds, it gives the analog maximum value (e.g. 20mA) at the minimum range point (e.g. 0 meters) and the analog minimum value (e.g. 4mA) at the maximum range point (e.g. 4 meters).
- **-Go to the next menu:** The magnet is read for more than 5 seconds. If the analog maximum point is not set at this stage, the point that was previously set as the analog maximum point will be valid.

ANALOG OUTPUT SCALE SETTINGS- SAMPLE SIGNAL OUTPUT GRAPHICS

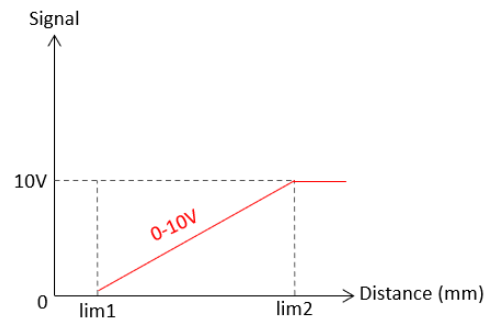
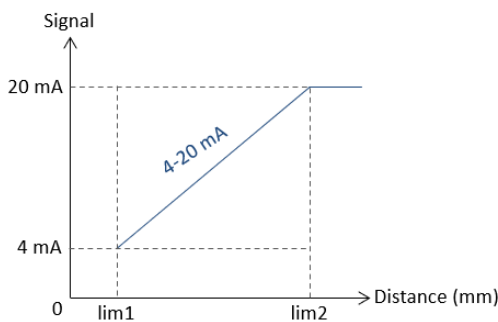

SWITCH OUTPUT CONFIGURATION WITH MAGNET

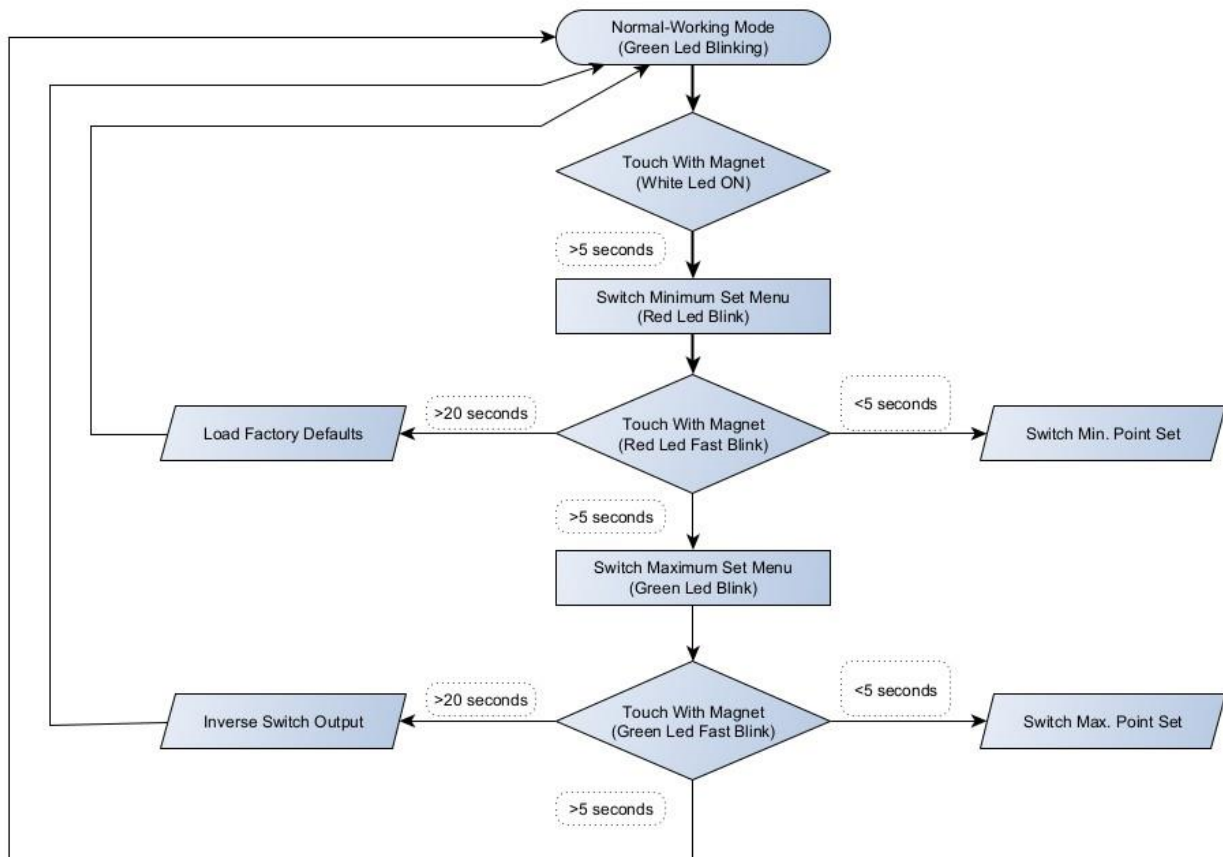

Zone where the adjustment magnet is approached

In this menu, the minimum and maximum distance range at which the Switch output of the product will be active is determined.

1. Setting the switch minimum point:

If the magnet is read for more than 5 seconds while the sign LED is green and flashing at one-second intervals, the switch is entered into its minimum setting. The indicator LED starts blinking red and at one-second intervals.

If the magnet is read for more than 1 second and less than 5 seconds, the LMS switch minimum point is saved.

If the magnet is read for more than 20 seconds, the device returns to factory settings and restarts.

- Go to the next menu: The magnet is read for more than 5 seconds. If the switch minimum point is not set at this stage, whatever point was previously set will be valid.

Default: Min:0mm, Max:1300mm

2. Setting the switch maximum point:

If the magnet is read for more than 5 seconds while the sign LED is green and flashing at one-second intervals, the switch is entered into its maximum setting. The indicator LED starts blinking green and at one-second intervals.

If the magnet is read for more than 1 second and less than 5 seconds, the LMS switch maximum point is saved.

If the magnet is read for more than 20 seconds, the device switch output is inverted. In other words, the transition is made from NO to NC.

If the magnet is read for more than 5 seconds, it returns to normal operating mode.

Warning(!) If a magnet is brought close to the magnetic reader area and the indicator light does not start blinking rapidly, it means that the magnet is not detected. It should be tried by changing the direction of the magnet, or tested with a stronger magnet.

ORDERING INFORMATION

-LDS 112

Model : 112 (Ø12 mm)

Measurement Range

Up to 2000 mm (upon request)

Electrical Connection

2M: 2m cable (standard)

S13M: M12-5 pin male Socket

**other options upon request*

Output Type

V0: 0-10 VDC

V1: 0-5 VDC

V3: 0.5-4.5 VDC

NV0 : 10-0 VDC

NV1: 5-0 VDC

NV3: 4.5-0.5 VDC

A0: 0-20 mA

A4: 4-20 mA

NA0 : 20-0 mA

NA4: 20-4 mA

C: CANopen

S2: RS-485

SW1: PNP open collector-NO

SW2: PNP open collector-NC



Note: 1 pcs 10x10cm reflector is provided as standard in the set.

REVISIONS HISTORY

REVISION	DATE	DESCRIPTION
A	07/07/2025	Creation of the document

CONTACT

MESUREX

13 Rue des Corroyés

78730 Saint Arnoult en Yvelines (France)

Tel : +33 (0) 1 30 41 23 62

Mail : mesurex@mesurex.fr

Web : www.mesurex.fr

